

Potain Igo 13

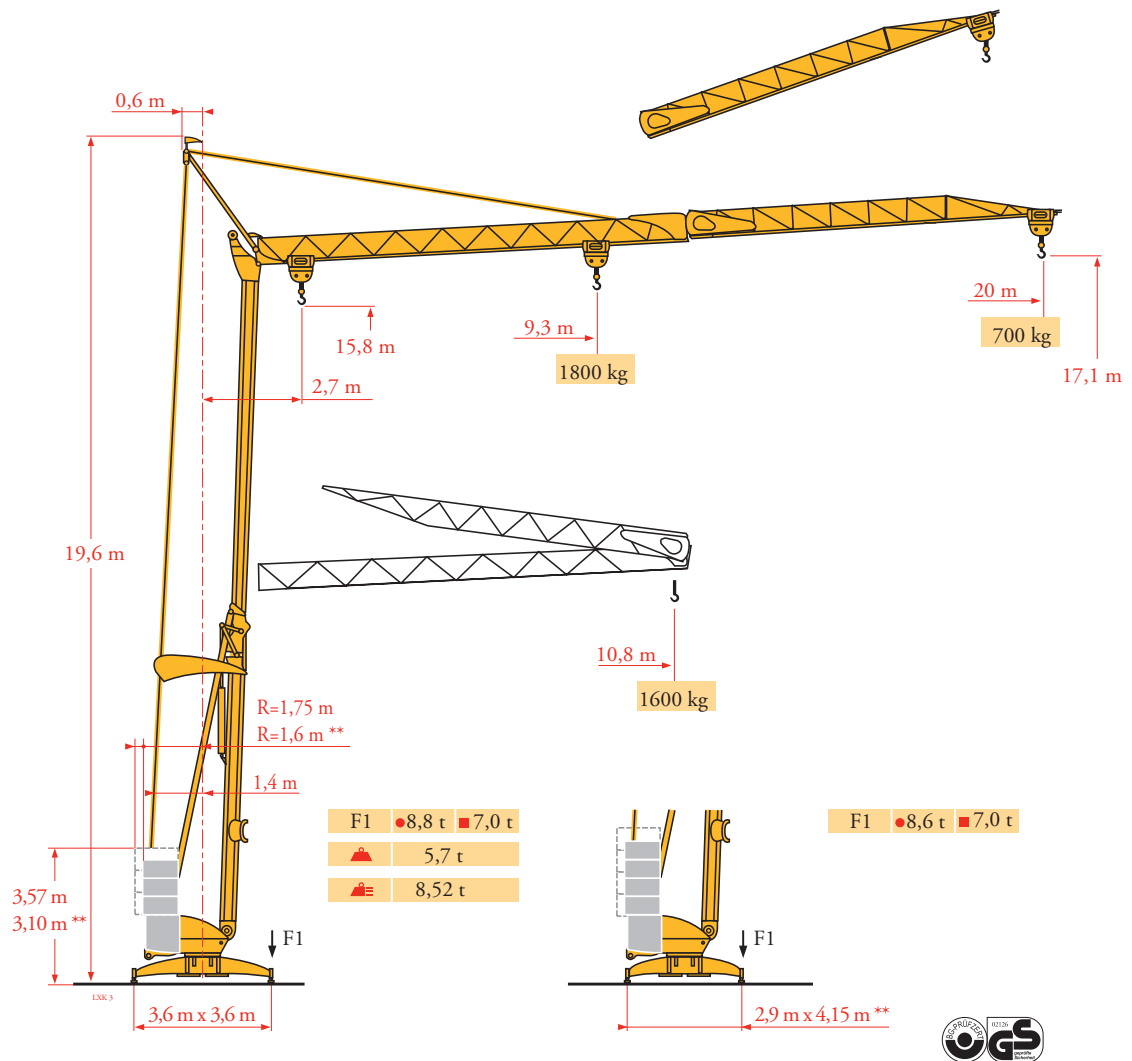

Courbes de charges
 Lastkurven
 Load diagrams
 Curvas de cargas
 Curve di carico
 Curva de cargas
 Диаграммы
 грузоподъемностей

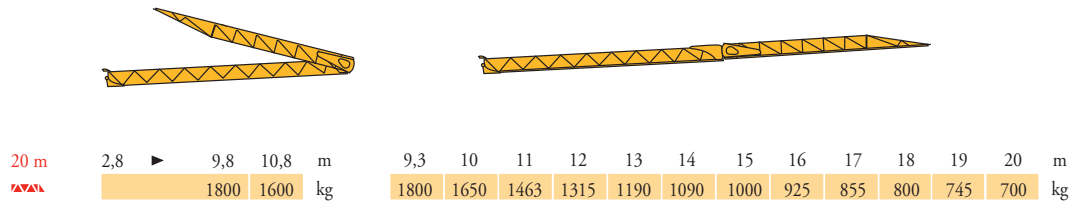

LXX3

Flèche relevée
 Ausleger in
 Steilstellung
 Luffing jib
 Flecha izada
 Braccio impennato
 Lança inclinada
 Маховая стрела

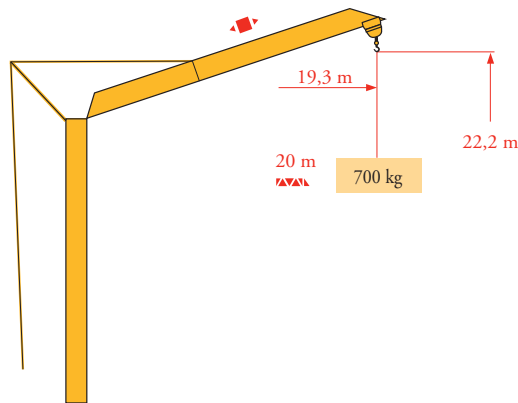

LXX4

<p>FR</p> <p>▲ Réactions en service ● Réactions hors service</p> <p>▲ A vide sans lest (ni train de transport) avec flèche et hauteur maximum.</p> <p>▲ Poids total du lest</p>	<p>DE</p> <p>Verfahrbare Laufkatze Reaktionskräfte in Betrieb Reaktionskräfte außer Betrieb</p> <p>Ohne Last, Ballast (und Transportachse), mit Maximalausleger und Maximalhöhe.</p> <p>Ballast-Gesamtgewicht.</p>	<p>EN</p> <p>Traversing trolley Reactions in service Reactions out of service</p> <p>Without load, ballast (or transport axes), with maximum jib and maximum height.</p> <p>Gross ballast weight.</p>	<p>ES</p> <p>Carro distribuidor Reacciones en servicio Reacciones fuera de servicio</p> <p>Sin carga, sin lastre, (ni tren de transporte), flecha y altura máxima.</p> <p>Peso total del lastre.</p>	<p>IT</p> <p>Carrellino distributore Reazioni in servizio Reazioni fuori servizio</p> <p>A vuoto, senza zavorra (ne assali di trasporto) con braccio massimo e altezza massima.</p> <p>Peso totale della zavorra.</p>	<p>PT</p> <p>Carro distribuidor Reações em serviço Reações fora de serviço</p> <p>Sem carga (nem trem de transporte)- sem lastro com lança e altura máximas.</p> <p>Peso total do lastro.</p>	<p>RU</p> <p>Грузовая тележка Реакции при работе Реакции в покое</p> <p>Вес без груза, балласта (или транспортных осей), с максимальной длиной стрелы и максимальной высотой.</p> <p>общий вес груза</p>
---	---	--	---	--	--	---

Mécanismes
Antriebe
Mechanisms
Mecanismos
Meccanismi
Механизмы

LXX4

							ch - PS hp	kW
	8 LVF 9 Optima	230 V 20 A 1	m/min	↑ 3,5 ↓ 3,5	↑ 7 ↓ 16	↑ 18 ↓ 36	3,3	2,4
		kg	1800	1800	700			
		230 V 32 A 2	m/min	↑ 3,5 ↓ 3,5	↑ 11 ↓ 16	↑ 25 ↓ 36	5,2	3,8
		kg	1800	1800	700			
		400 V 3	m/min	↓ 3,5	↓ 16	↓ 36	7,5	5,5
		kg	1800	1800	700			
	1 DVF 4	-	m/min	14 - 28			1,5	1,1
	RVF 20	-	tr/min U/min rpm	0 → 1			1,5	1,1

IEC 60204-32	kVA
230 V(+6% -10%) 50 Hz 400 V(+10% -10%) 50 Hz / 480 V(+ 6% -10%) 60 Hz	230 V 20 A : 4,6 kVA 230 V 32 A : 7,4 kVA 400 V / 480 V : 11 kVA

8 LVF 9 Optima

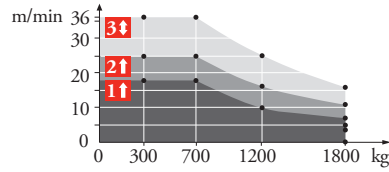

Montage
Montage
Erection
Montaje
Montaggio
Montagem
Монтаж

LXX3

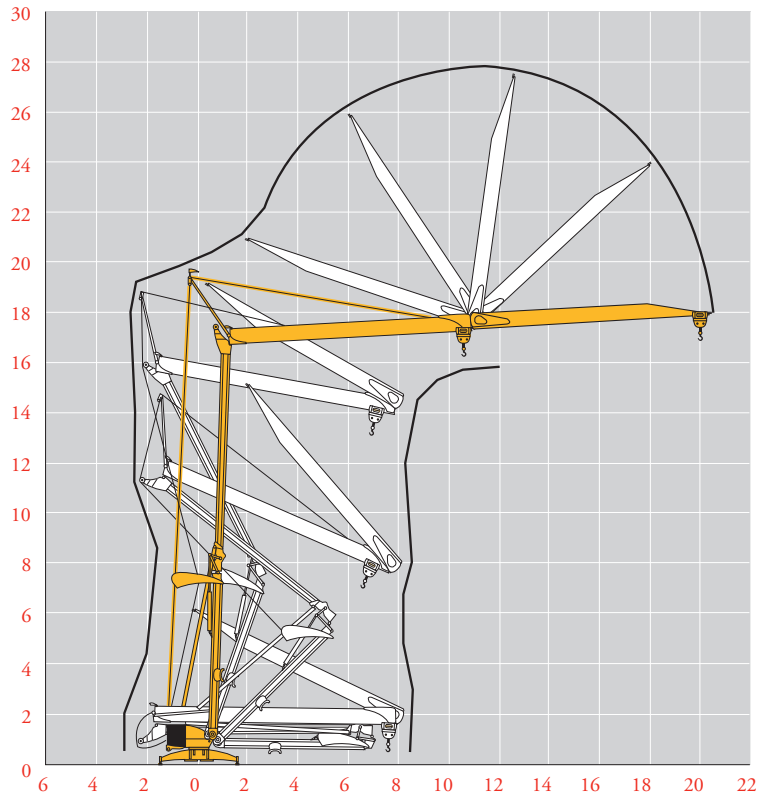

FR

- Levage
- Distribution
- Orientation
- 50 Hz Monophasé

DE

- Heben
- Katzfahren
- Schwenken
- 50 Hz Einphasige

EN

- Hoisting
- Trolleying
- Slewing
- 50 Hz Single phase

ES

- Elevación
- Distribución
- Orientación
- 50 Hz Monofásica

IT

- Sollevarmento
- Ditribuzione
- Rotazione
- 50 Hz Monofase

PT

- Elevação
- Distribuição
- Rotação
- 50 Hz monofásica

RU

- Подъем
- Перемещение каретки
- Поворот
- Однофазное напряжение 50Hz

Transport
 Transport
 Transport
 Transporte
 Trasporto
 Transporte
 Транспортировка

LXK 5

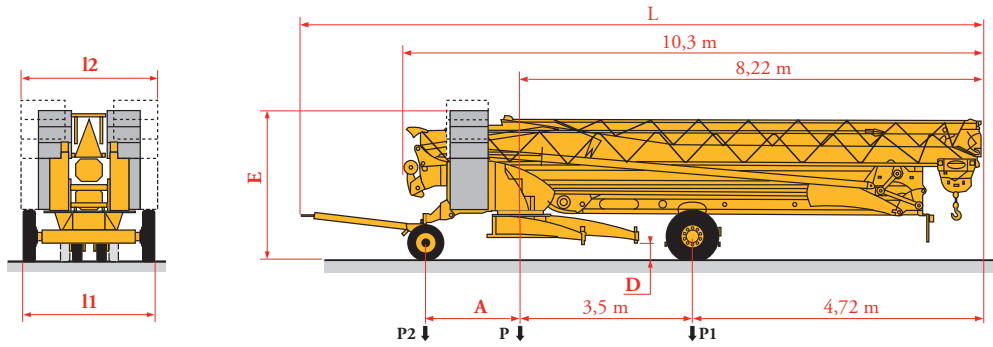

	Km/h	A (m)	D (m)	E (m)	L (m)	I1 (m)	I2 (m)	P (kg)	P1 (kg)	P2 (kg)
DS62/S81	10	1,93	0,33/0,18	2,98/2,83	12,30	2,20	2,48/2,2**	9340	4970	4370
DJ100/S120	10	2,03	0,33/0,18	3,29/3,14	12,76	2,40	2,48/2,2**	15665	6370	9295
DS65/S65	25	1,93	0,33/0,18	2,98/2,83	12,30	2,00	2,48/2,2**	9700	5100	4600
DJ105/S125	25	2,03	0,33/0,18	3,29/3,14	12,76	2,40	2,48/2,2**	15955	6580	9375
... **										

FR



Transport grue toute lestée.

**

Voir documentations techniques.

DE

Krantransport mit voller Ballastierung.

Siehe technische Dokumentation.

EN

Transport of crane with full ballast.

See technical documentations.

ES

Transporte grúa completamente lastrada.

Consulte la documentación técnica.

IT

Trasporto con gru completamente zavorrata.

Vedere la documentazione tecnica.

PT

Transporte de grua totalmente balastada.

Consultar documentações técnicas.

RU

Перевозка крана с полным балластом

см. техническую документацию



Document commercial non contractuel. Pour toute information technique se référer à la notice correspondante.

Unverbindliches Vertriebsdokument. Für technische Informationen, siehe die entsprechenden Anweisungen.

This commercial document is not legally binding. For any technical information, please refer to the corresponding instructions.

Documento comercial no contractual. Para cualquier información técnica, ver la noticia correspondiente.

Documento commerciale non vincolante. Per tutte le informazioni tecniche fare riferimento al catalogo istruzioni.

Documento comercial não contractual. Para qualquer informação técnica complementar consultar as respectivas instruções.

Этот коммерческий документ не является юридически обязательным. Для получения технической информации, см. соответствующие инструкции.



Manitowoc - Americas - World Headquarters
 2400 S. 44th Street • Manitowoc • WI 54220 USA
 Tel: +1 920 684 4410 • Fax: +1 920 652 9778

Manitowoc - Europe, Middle East & Africa
 Ecully, France
 18, rue de Charbonnières B.P. 173 • 69132 ECULLY Cedex • FRANCE
 Tel: +33 (0)4 72 18 20 20 • Fax: +33 (0)4 72 18 20 00

Manitowoc - Asia Pacific
 16F Xu Hui Yuan Building,
 1089 Zhongshan No.2 Road (S) • Shanghai 200030 China
 Tel: +86 21 6457 0066 • Fax: +86 21 6457 4955

REF. 2003 48 LXK 7