

Potain Igo MA 13

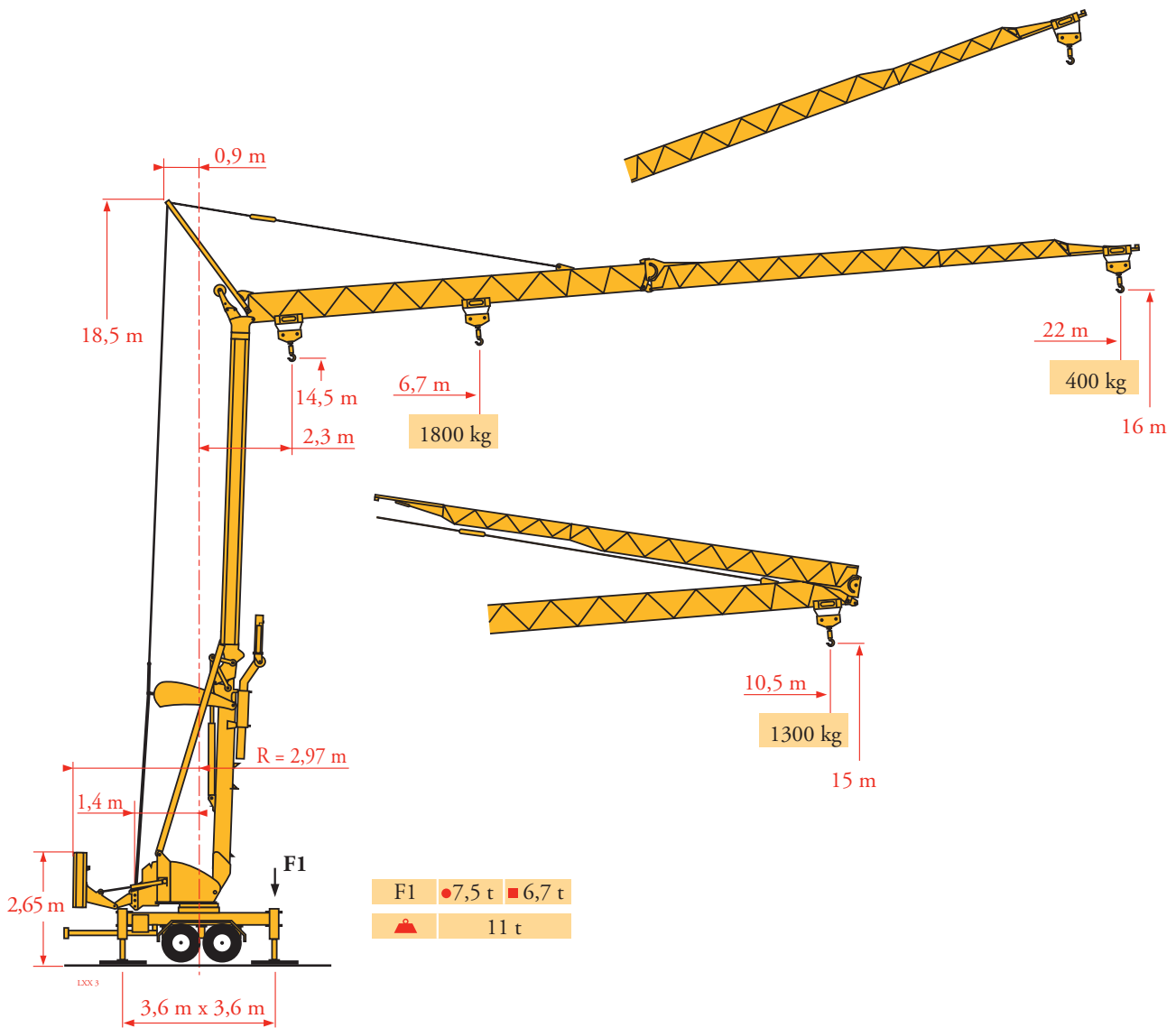

Courbes de charges
 Lastkurven
 Load diagrams
 Curvas de cargas
 Curve di carico
 Curva de cargas
 Диаграммы грузоподъемностей

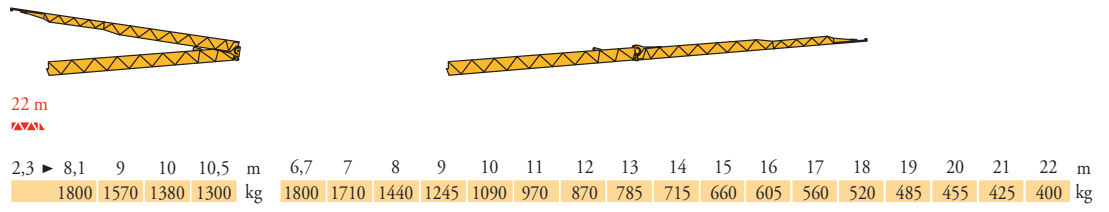

Flèche relevée
 Ausleger in Steilstellung
 Luffing jib
 Flecha izada
 Braccio impennato
 Lança inclinada
 Маховая стрела

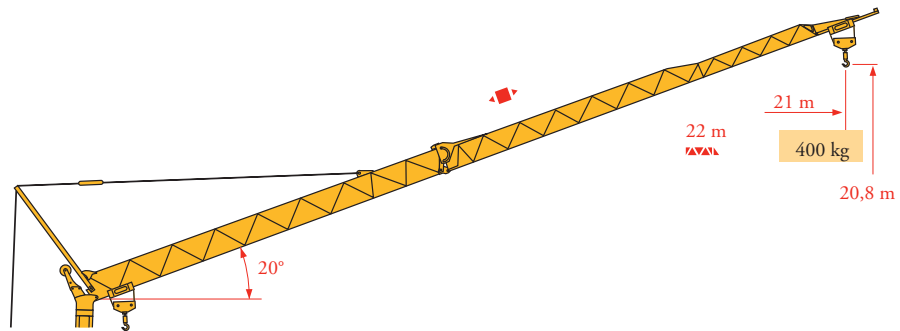

- | | | | | | | |
|--|---|---|---|--|---|--|
| <p>FR</p> <p>Chariot distributeur
 Réactions en service
 Réactions hors service</p> <p>A vide sans lest (ni train de transport) avec flèche et hauteur maximum.</p> | <p>DE</p> <p>Verfahrbare Laufkatze
 Reaktionskräfte in Betrieb
 Reaktionskräfte außer Betrieb</p> <p>Ohne Last, Ballast (und Transportachse), mit Maximalausleger und Maximalhöhe.</p> | <p>EN</p> <p>Traversing trolley
 Reactions in service
 Reactions out of service</p> <p>Without load, ballast (or transport axes), with maximum jib and maximum height.</p> | <p>ES</p> <p>Carro distribuidor
 Reacciones en servicio
 Reacciones fuera de servicio</p> <p>Sin carga, sin lastre, (ni tren de transporte), flecha y altura máxima.</p> | <p>IT</p> <p>Carrellino distributore
 Reazioni in servizio
 Reazioni fuori servizio</p> <p>A vuoto, senza zavorra (ne assali di trasporto) con braccio massimo e altezza massima.</p> | <p>PT</p> <p>Carro distribuidor
 Reações em serviço
 Reações fora de serviço</p> <p>Sem carga (nem trem de transporte)- sem lastro com lança e altura máximas.</p> | <p>RU</p> <p>Грузовая тележка
 Реакции при работе
 Реакции в покое</p> <p>Вес без груза, балласта (или транспортных осей), с максимальной длиной стрелы и максимальной высотой.</p> |
|--|---|---|---|--|---|--|

Mécanismes
Antriebe
Mechanisms
Mecanismos
Meccanismi
Mecanismos
Механизмы

LXX4

							ch - PS hp	kW
	8 LVF 9 Optima	230 V 20 A 1	m/min	↑ 3,5 ↓ 3,5	↑ 7 ↓ 16	↑ 18 ↓ 36	3,3	2,4
			kg	1800	1800	700		
		230 V 32 A 2	m/min	↑ 3,5 ↓ 3,5	↑ 11 ↓ 16	↑ 25 ↓ 36		
		kg	1800	1800	700	5,2	3,8	
		400 V 3	m/min	↑ 3,5	↑ 16	↑ 36	7,5	5,5
			kg	1800	1800	700		
	1 DVF 4	-	m/min	14 - 28			1,5	1,1
	RVF 20	-	tr/min U/min rpm	0 → 1			1,5	1,1

IEC 60204-32	kVA
230 V(+6% -10%) 50 Hz 400 V(+10% -10%) 50 Hz / 480 V(+ 6% -10%) 60 Hz	230 V 20 A: 4,6 kVA 230 V 32 A: 7,4 kVA 400 V/ 480 V: 11 kVA

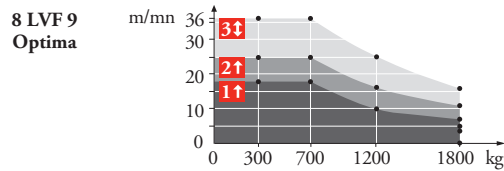

Montage
Montage
Erection
Montaje
Montaggio
Montagem
Монтаж

LXX3

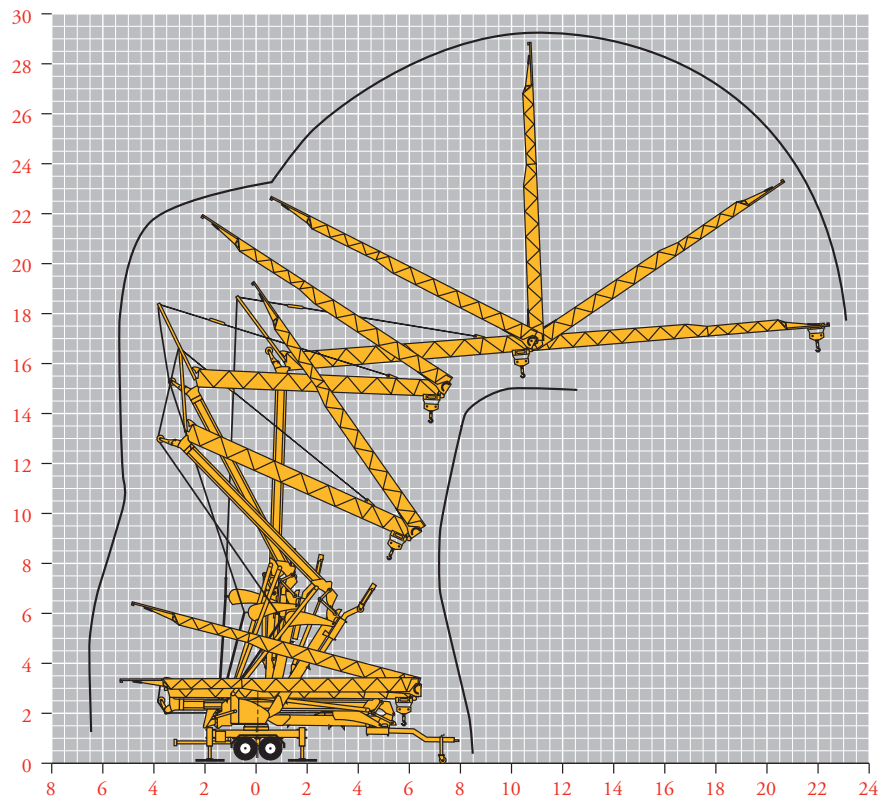

FR

Levage
 Distribution
 Orientation
 50 Hz Monophasé

DE

Heben
Katzfahren
Schwenken
50 Hz Einphasige

EN

Hoisting
Trolleying
Slewing
50 Hz Single phase

ES

Elevación
Distribución
Orientación
50 Hz Monofásica

IT

Sollevarmento
Distribuzione
Rotazione
50 Hz Monofase

PT

Elevação
Distribuição
Rotação
50 Hz monofásica

RU

Подъем
Перемещение каретки
Поворот
Однофазное напряжение 50Hz

Transport
 Transport
 Transport
 Transporte
 Trasporto
 Transporte
 Транспортировка

LXX 4

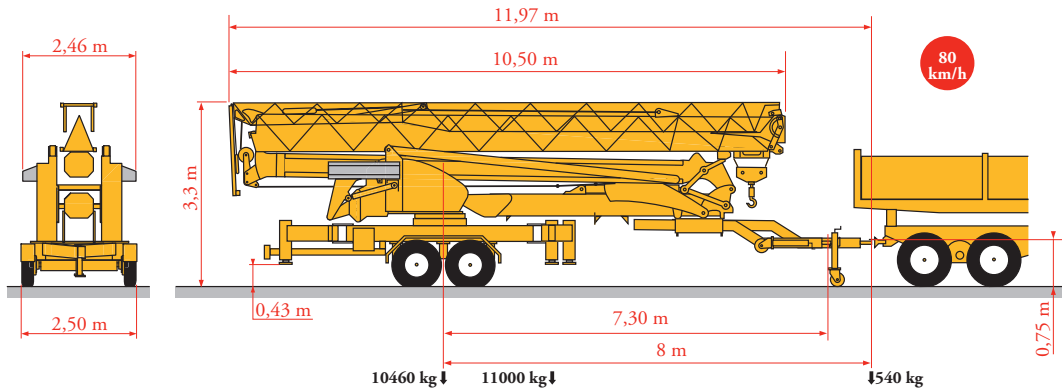

Document commercial non contractuel. Pour toute information technique se référer à la notice correspondante.

Unverbindliches Vertriebsdokument. Für technische Informationen, siehe die entsprechenden Anweisungen.

This commercial document is not legally binding. For any technical information, please refer to the corresponding instructions.

Documento comercial no contractual. Para cualquier información técnica, ver la noticia correspondiente.

Documento commerciale non vincolante. per tutte le informazioni tecniche fare riferimento al catalogo istruzioni.

Documento comercial não contractual. Para qualquer informação técnica complementar consultar as respectivas instruções.

Этот коммерческий документ не является юридически обязательным. Для получения технической информации, см. соответствующие инструкции.



Manitowoc - Americas - World Headquarters
 2400 S. 44th Street • Manitowoc • WI 54220 USA
 Tel: +1 920 684 4410 • Fax: +1 920 652 9778

Manitowoc - Europe, Middle East & Africa
 Ecully, France
 18, rue de Charbonnières B.P. 173 • 69132 ECULLY Cedex • FRANCE
 Tel: +33 (0)4 72 18 20 20 • Fax: +33 (0)4 72 18 20 00

Manitowoc - Asia Pacific
 16F Xu Hui Yuan Building,
 1089 Zhongshan No.2 Road (S) • Shanghai 200030 China
 Tel: +86 21 6457 0066 • Fax: +86 21 6457 4955

REF: 2003 48 LXX 6